



THERMES BALANCED FLUE ROOM SEALED GAS FIRE

USER INSTRUCTIONS

INSTALLATION INSTRUCTIONS

SERVICE INSTRUCTIONS

Do not use this appliance if the front glass panel is broken, removed or fitted incorrectly.

It is a regulation that these instructions be handed to the customer after installation is complete. It is also the responsibility of the installation engineer to ensure that the customer is able to fully operate the appliance and is aware of any cleaning or maintenance requirements.

Model numbers: F-071XX1 MANUAL for use on Natural Gas (G20) at a supply pressure of 20 mbar in GB

Model numbers: F-071XX2 SLIDE for use on Natural Gas (G20) at a supply pressure of 20 mbar in GB

(X denotes trim type)

**THESE INSTRUCTIONS ARE TO BE LEFT WITH
THE CUSTOMER AFTER INSTALLATION**

CONTENTS

Regulatory Information and Installation Requirements	3
Regulatory requirements for Flue Terminal installation.....	4
Siting the Appliance and preparing opening.....	5
Clearances from combustible shelf.....	7
Elevated installation.....	8
Preparing the gas supply for the appliance	8
Fixing the Appliance and the Flue.....	9
Connecting the appliance to the gas supply.....	11
Appliance Data Information.....	12
Removal of glass panel.....	13
Checking Operation of Appliance	14
Completing the Installation	15
Cleaning Instructions	16
Service Instructions	17
User Instructions	19
Coal Layout Instructions	20
Appliance Commissioning Checklist	22
Product Fiche	23
Spare Parts List	24
Manufacturer's Contact Details	24

REGULATORY INFORMATION AND INSTALLATION REQUIREMENTS

THE FOLLOWING MUST BE NOTED PRIOR TO THE INSTALLATION OF THIS APPLIANCE.

This gas appliance **MUST** be installed by a GAS SAFE registered installer by law. It must be installed in accordance to these installation instructions and the GAS SAFETY (Installation & Use) REGULATIONS 1998 as amended. Non compliance of this law may lead to prosecution and it is in the interest of you and your family that this condition is observed.

The installation of this appliance must be in accordance with the relevant parts of the LOCAL AND NATIONAL BUILDING REGULATIONS as issued by the Department of the Environment or BUILDING STANDARD (Scotland Consolidation) REGULATIONS issued by the Scottish Development Department and the following relevant British Standards:

BS5871	Part 2 Installation of Inset Live Fuel Effect Gas Fires
BS5440	Parts 1 & 2 Installation of Flues and Ventilation
BS6891	Installation of Gas Pipe-work
IS813:1996	Domestic Gas Installation (Republic of Ireland)

Prior to installation ensure that the gas supply is compatible with the appliance, this appliance must only be used on **natural gas** at a supply pressure of 20 mbar as marked on the data plate on the appliance and the carton. **Modification to alternative gas types is not possible with this appliance.**

If the product is being installed into a timber framed building then advice should be sought specifically as building alterations may void any cover supplied by NHBC. If in doubt contact your local building and planning authority. Further information can be obtained from the publication: Gas Installations in Timber Frame Buildings : IGE/UP/7 Edition 2.

The efficiency of this appliance has been tested to EN613 and the result is 86% net (78% gross). This efficiency value has been verified by Kiwa (0558). This efficiency value can be used for SAP (Standard Assessment Procedure) for energy rating of UK dwellings.

Ventilation

No purpose made ventilation is required for this appliance

This appliance must only be installed on to a suitable hearth with a minimum thickness of 12mm. The appliance must not be installed directly onto carpet or other combustible floor materials. The fireplace surround (back-panel) must have a temperature rating of at least 150°C.

Do not place soft wall coverings (i.e. embossed papers etc,) furniture or other combustible items too close to the fires as they may discolour or scorch.

Do not place or throw rubbish or otherwise on the fuel-bed.

Do not place any combustible materials or flooring (i.e. carpets etc,) on any part of the hearth.

It is very important that you arrange for a GAS SAFE registered engineer to service your appliance every year – during this service the engineer will remove the appliance and check for debris, check the operation of the flue and check the operation of the appliance. This is important for you and your families safety.

NEVER place more ceramic components onto the fuel bed than specified in the instructions.

NEVER touch the glass panel or metal parts surrounding the glass when the fire is running or if it has recently been in operation—these components retain heat and may cause burns. Leave the appliance to sufficiently cool prior to any contact.

WARNING: This appliance has very hot surfaces when in use and as with all heating appliances a fireguard should be used for the protection of children, the elderly, infirm and pets. The fireguard should conform to BS8423 : 2002 (Fireguards or use with Gas Heating Appliances).

Important Note: It is quite normal for a flame effect gas appliance to experience a small amount of soot or staining to some parts of the fuel effect components. If this becomes excessive it may be because the fuel bed is not fitted correctly—this should be checked according to these installation instructions prior to contacting a service engineer.

REGULATORY REQUIREMENTS FOR FLUE TERMINAL LOCATION

Figure 1

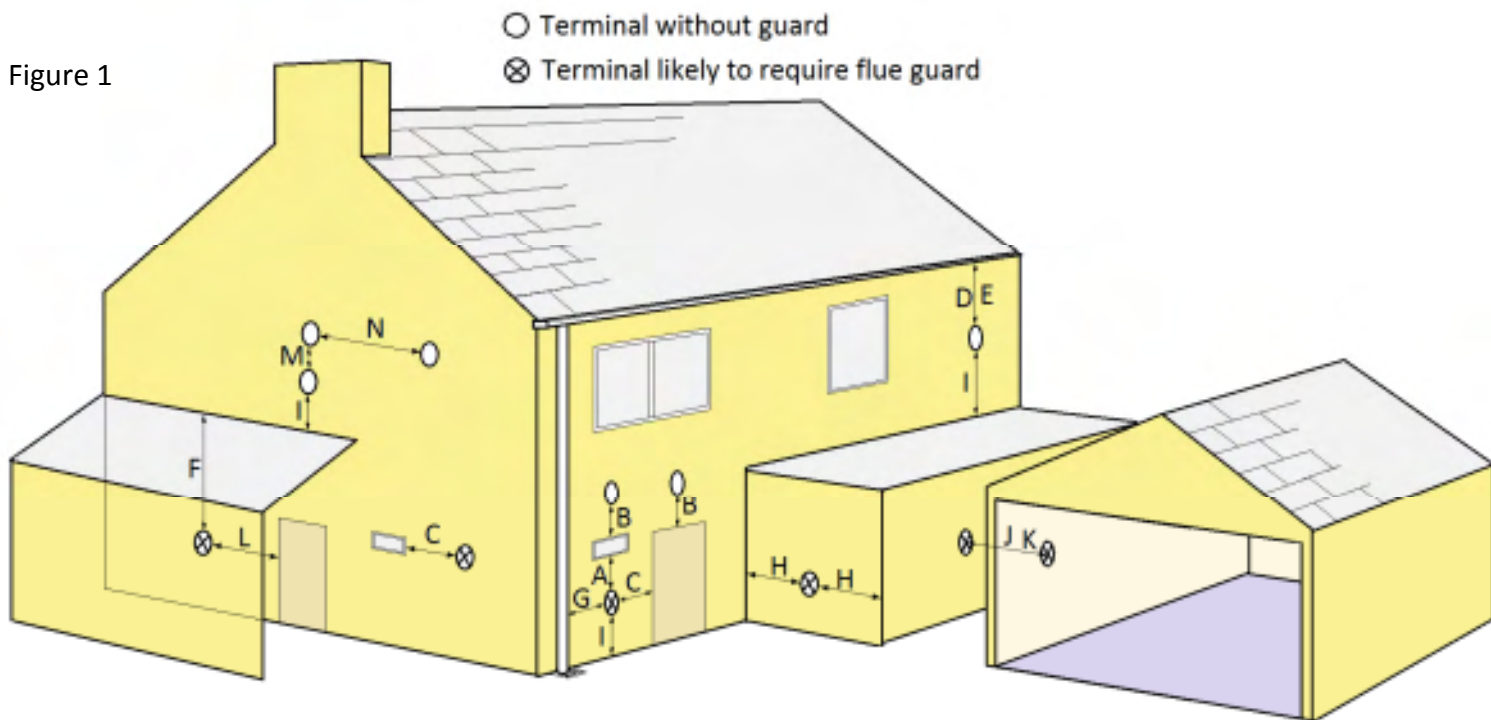

Key	Terminal Position	Minimum Distance
A*	Directly below an opening, airbrick, opening window etc.	300mm
B*	Above an opening, air brick, opening window etc.	300mm
C*	Horizontally to an opening, air brick opening window etc.	300mm
D	Below gutters, soil pipes or drains.	300mm
E	Below eaves.	300mm
F	Below balconies or car port roof.	600mm
G	From a vertical drain pipe or soil pipe.	300mm
H**	From an internal or external corner	600mm
I	Above ground, roof, or balcony level.	300mm
J	From a surface facing the terminal.	600mm
K	From a terminal facing a terminal	600mm
L	From an opening in a car port (e.g. door, window) into dwelling.	1200mm
M	Vertically from a terminal on the same wall.	1500mm
N	Horizontally from a terminal on the same wall.	300mm

* In addition, the terminal should not be nearer than 300mm to an opening in the building fabric formed for the purpose of accommodating a built-in element such as a window frame or door frame.

** The reference to external corners does not apply to building protrusions not exceeding 450mm, such as disused chimneys on external walls.

A terminal guard is supplied with this appliance. It is a requirement in England and Wales that this a guard be fitted where the flue terminal may come into contact with people near the building or be susceptible to damage.

In the republic of Ireland the installation must conform to the relevant sections of IS813 'Domestic Gas Installations'.

Hearth Products recommend that the terminal guide be fitted in any area where it may be damaged or contact could be made with the flue terminal.

SITING THE APPLIANCE AND PREPARING THE OPENING

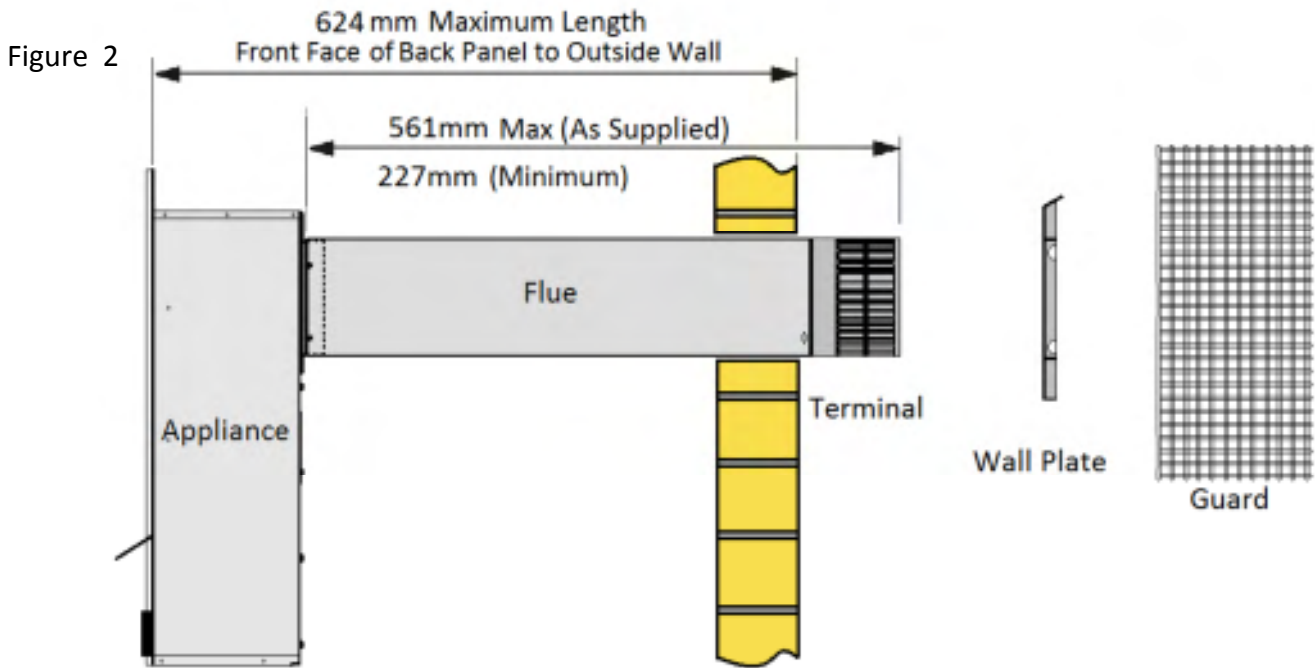

Figure 2 shows the maximum length flue attached to the appliance. If the distance from the front face of the back panel to the outside wall exceeds 624mm the installation cannot proceed. In most installations the flue section will need to be cut to the appropriate size. Any reduction to flue length must be removed from the end opposite the terminal and the three holes then re-drilled to fix the flue to the appliance—use the holes in the waste section of flue as a guide. Take note of the orientation of the flue pipe as it should be installed correctly—see marking on flue.

DO NOT CUT THE FLUE YET. ONCE THE APPLIANCE CAN BE PLACED IN POSITION THE FLUE LENGTH CAN BE CHECKED BEFORE CUTTING—REPLACEMENT FLUES WILL BE CHARGED FOR IF THE FLUE IS CUT INCORRECTLY.

FLUE CUTTING INFORMATION IS ON PAGE 8 OF THESE INSTRUCTIONS

Figure 3 shows the inner brickwork removed to accept the appliance. Note centre of the flue hole must be 6" (minimum) diameter and located at a height of 417mm from the hearth or installation surface. Use the template supplied to aid the installation—see page 6 of these instructions.

A clearance of at least 20mm must remain between the rear face of the appliance and the inner face of the outer brickwork—as shown in Fig 3 below.

Figure 3

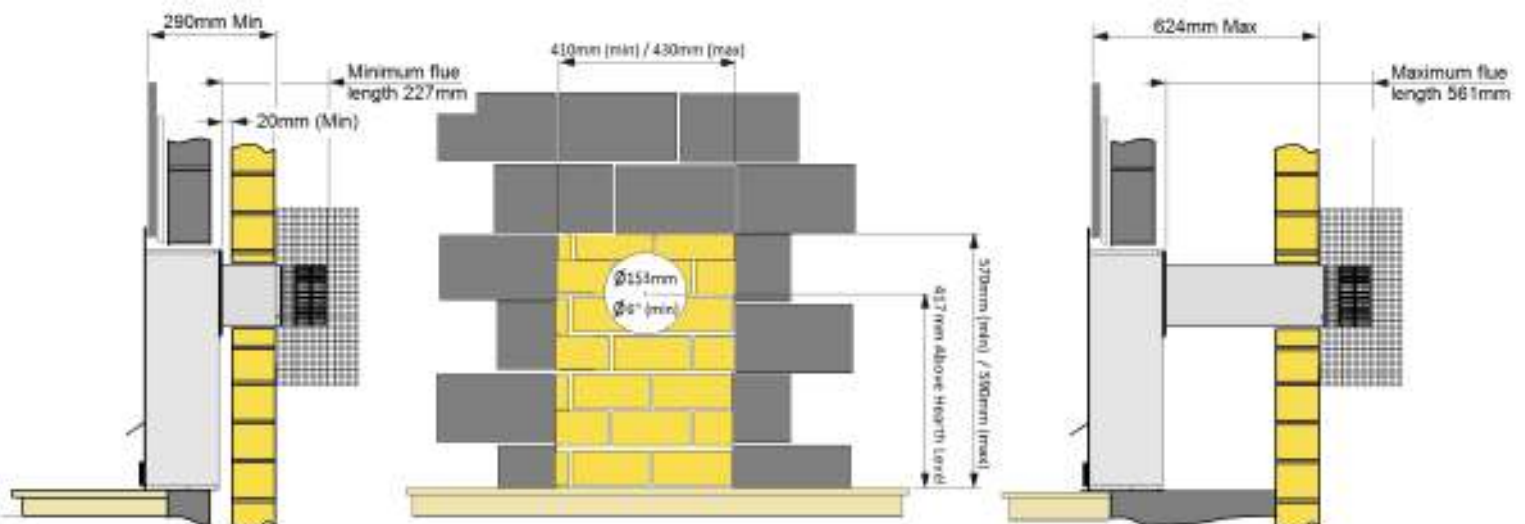

It may be necessary to install a lintel above the cavity that has been created. If a lintel is required to support the recess in the inner leaf (brickwork) then it should either be steel or reinforced precast concrete. The lintel should be the depth of the inner brickwork and be approximately 700mm long.

Ensure that all dust and rubble is removed from the area. If any wall cladding exists ensure that it is removed and then pack the cavity in the area of the opening with at least 5" (125mm) of Rockwool above and at each side. If there is granular cavity wall insulation this Rockwool will prevent it falling into the cavity it may also be necessary to fit a piece of Superlux board or equivalent to seal the top of the cavity to prevent any granular insulation from falling—if this method is used ensure that the board slopes down towards the outside wall to enable any moisture to run outwards.

Timber Frame Buildings

If the appliance is being installed into a timber framed building the hole through which the flue will pass must have a steel sleeve positioned such that a minimum 25mm air gap exists between the outside diameter of the flue pipe and the metal sleeve – in addition, contact your local building and planning authority (see safety notes on page 3).

Cutting the Hole in Outer Brick Work

Use the template supplied with the appliance to confirm the position.

Ensure that the template is fixed to the wall at the correct height, allowing for the hearth height after its' installation. Mark out the cut-out for the inner brickwork and the flue centre line. Using a core drill is the quickest and easiest method to produce the hole required for the flue in the outer wall. Alternatively a hammer and cold chisel can be used however care should be taken not to damage brickwork surrounding the flue pipe as this will be visible after installation is complete. If damage is caused to outer brickwork this should be made good when completing the installation. Check carefully to ensure that hole is made in the correct position, the hearth height or installation height of the base of the appliance must be known first. See the drawing on page 5, Figure 3. Check also with the terminal position requirements on page 4.

When drilling the hole it is advisable that a pilot hole is drilled first. The hole should be drilled to approximately half the brick depth then complete the hole by drilling from the outside of the building, this will ensure that the entry and exit of the hole are clean.

Ensure that the flue hole is drilled horizontally or in a slightly upward inclination. DO NOT install with the flue angled downwards.

The template supplied also shows the correct position for the eye bolts for the wire fixing system.

Installation Tip

Use the cardboard sleeve supplied in the packaging of the flue to line the outer brick flue hole. The flue can then be pushed through the hole to check fit and alignment without causing any damage to the flue or terminal.

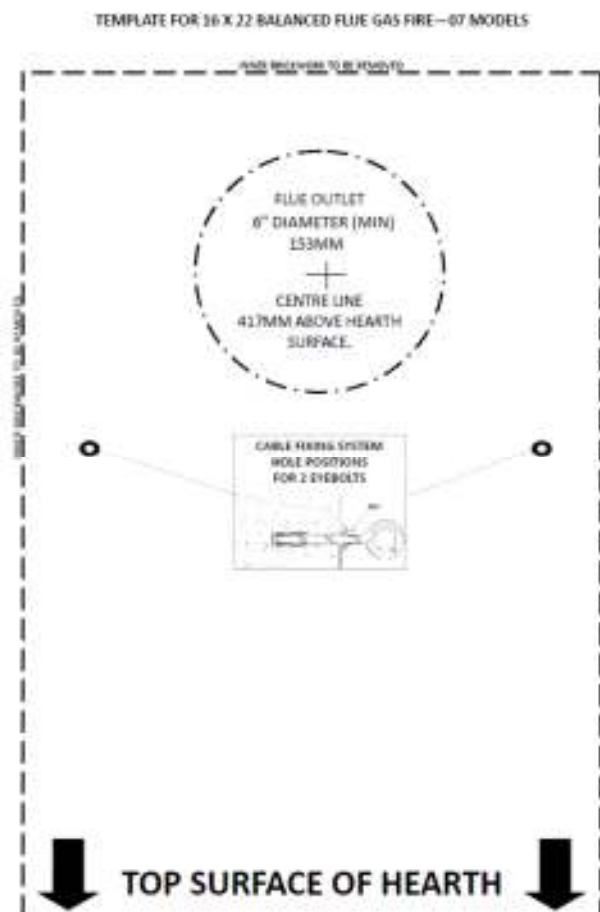

This fire is suitable for fitting to non-combustible fireplace back panels with a temperature rating of at least 150°C. (This is also known as CLASS“O” - If in doubt please contact the supplier of the back panel to check suitability. It is recommended that the back panel be constructed of 3 sections with joints across the upper level of the fireplace section to allow for expansion and contraction. The installation of this appliance into an unsuitable back panel, where this component subsequently cracks, will not be deemed to be a fault of the appliance.

The fire opening must be between the dimensions shown in the figure 4 below. A flat face of a minimum 520mm wide and 620mm high must be provided around this opening to ensure a good seal is formed. Ensure the base of the fireplace opening is flat and level with the hearth surface (if applicable) to ensure a secure and aligned installation of the appliance.

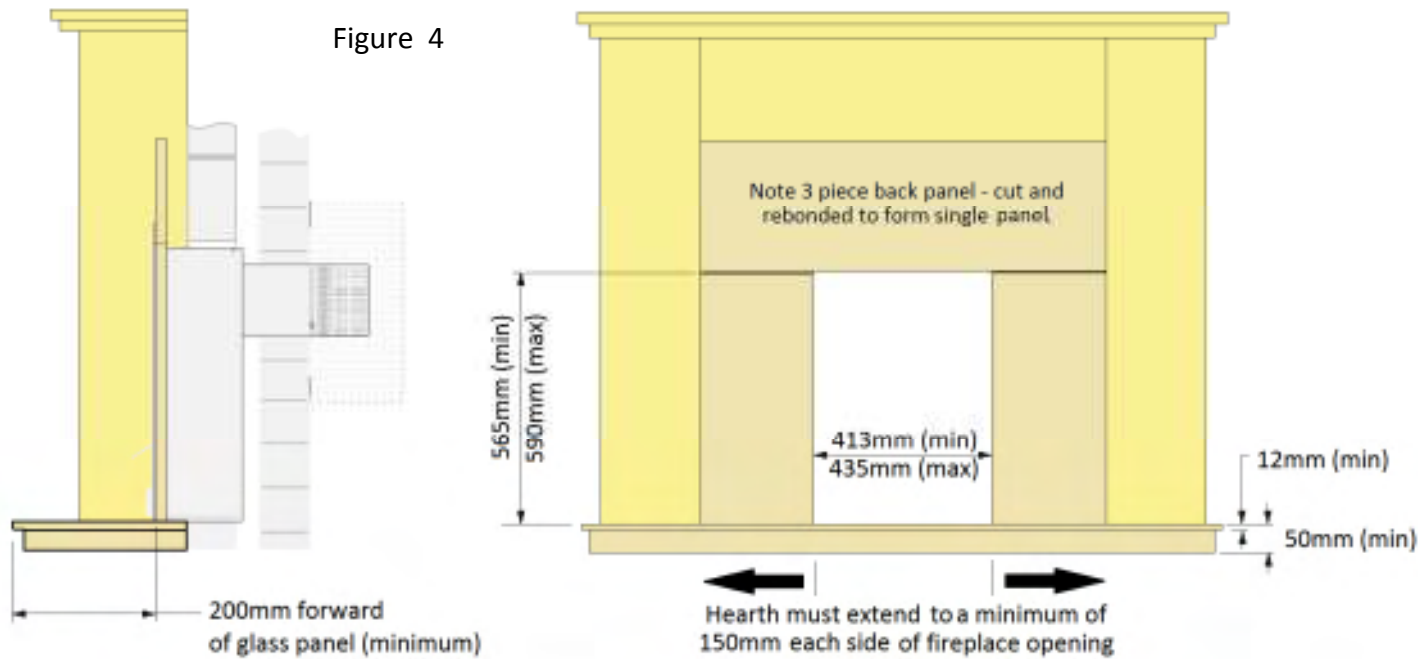

Seal the Gap behind the back panel (Hearth Mounted installations using rebated mantel).

If a gap exists between the rear of the back panel and the wall (due to mantel rebate) this gap should be sealed with bonding or similar to prevent heat from accumulating in this area and affecting mantel shelf temperatures.

Combustible Shelf

This appliance may be fitted below a surround with a combustible shelf providing the following dimensional criteria is met:

There must be a minimum distance of 180mm from the top of the appliance to the underside of the shelf. The shelf must not project more than 150mm from the mounting surface of the appliance into the room. If the shelf projects more than 150mm then the distance between the top of the appliance and the underside of the shelf must be increased accordingly; for every 10mm of projection above 150mm the distance between the fire and shelf must be increased by 5mm

Shelf Protrusion	Min. Distance Between Fire and Shelf
150mm	180mm
160mm	185mm
170mm	190mm
180mm	195mm
190mm	200mm
200mm	205mm

Fireplace Opening when appliance is to be elevated (Hole in the Wall Installation)

This appliance may be installed such that the base of the appliance sits at an elevated position. For this type of installation it is important that the fret to the appliance is either integral with the trim, is fixed to the appliance securely or a small hearth surface is constructed at the base of the opening for the fret to sit upon. If such a hearth is constructed it must be a minimum of 480mm in width and 100mm deep.

A non combustible back panel must be used during this type of installation. Opening sizes are the same as those used for a conventional hearth mounted installation—see Figure 3. It is recommended that this back panel provides a border of a minimum of 100mm around the opening.

It is always important to ensure that the appliance is fixed securely to the fireplace opening so that no movement of the ceramics takes place when the appliance is operated. In addition it is imperative that **ONLY** fascia/trim arrangements that are supplied by Hearth Products are deemed suitable to be used with Hearth Products appliances in a 'hole in the wall' installation.

THE INSTALLER MUST INFORM THE USER OF THE FOLLOWING IMPORTANT NOTICES AFTER A HOLE IN THE WALL INSTALLATION HAS BEEN UNDERTAKEN.

1. The user must be made aware to fit a secure fireguard where the room is used by elderly, infirm, infants, young children or pets.
2. The customer should be advised to fit a hearth panel or a physical barrier in accordance with BS5871-2. Should this advice not be followed the customer should be advised to give due to consideration to the safety of the occupants in the room where the appliance is to be installed. The customer should be informed that the glass panel on this appliance gets extremely hot when in use.
3. The user must be made aware to keep the area immediately in front of the appliance clear of combustibles items. This does not include the floor covering however such covering should be fixed.
4. The user must ensure that the ceramic fuel bed is maintained in the correct condition of installation, especially after cleaning. If the fuel bed is removed for cleaning or maintenance the ceramics should be checked for secure placing and tested for movement during appliance operation.
5. The user must ensure that other occupants of the room where the appliance is installed are notified to not get unnecessarily close to the appliance when in use or to position any furniture or appliances too close to the fire.

Preparing the Gas Supply for the Appliance

The gas supply can be prepared for a concealed fitting from the rear. In all installation conditions the gas connection should be provided using 8mm (O/D) copper tubing. If the concealed installation method is chosen, there are three optional entry points at the rear/side of the appliance. The relevant 'knock-out' entry point should be removed to allow the gas supply to enter the appliance. **No soldered joints** should be used within the firebox of the appliance.

A gas soundness test should be performed to ensure that the existing pipe work in the property is sound.

The gas connection is detailed on page 11. The connection to the appliance will be made using the 8mm restrictor isolation valve supplied with the appliance. This restrictor elbow is supplied loose and should be fitted as per the label on the instruction packet.

If any part of the gas pipe will be situated in the cavity it **MUST** be sleeved in accordance with BS6891. flexible sleeving is permitted.

Fixing the Appliance.

If the appliance is being installed with a spacer kit, this should be attached to the appliance using the screws included and the fire retardant foam strip which is supplied with the appliance should be affixed to the rear face of the spacer. Do not use any permanent sealing substance as this will invalidate warranty.

Cable Fixing System (Supplied as standard)

This appliance is best installed with the cable fitting system which is supplied in the standard fitting pack. The fitting system comprises two (2) eyebolts and two (2) fixing cables, the appliance is secured with the clamping nipples on each side.

Simply drill and fit the eyebolts in the positions shown on the template. This diagram shows the details of the holes required to secure the eyelets.

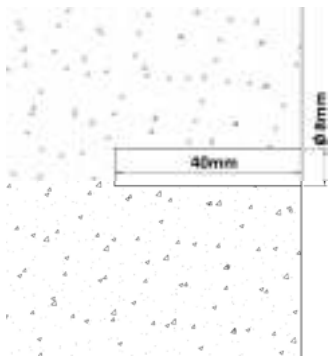

Drill a hole 8mm dia. by 40mm deep. Ensure all the debris is removed from the hole. Use a wrench to twist the nut tightly until the anchor is solid and reliable.

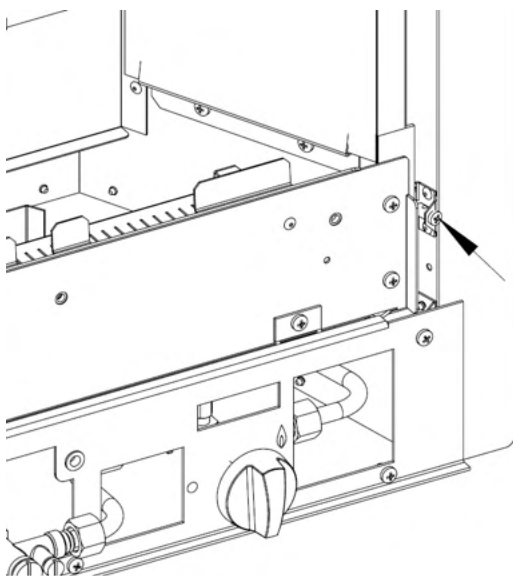
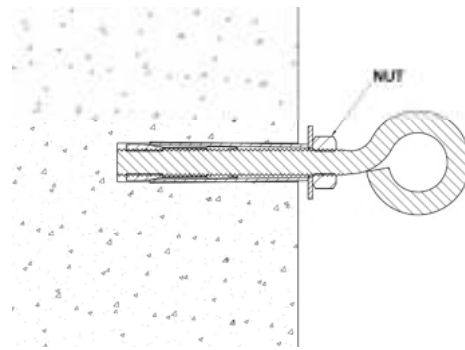

Loosen the nipple screw on each side of the appliance.

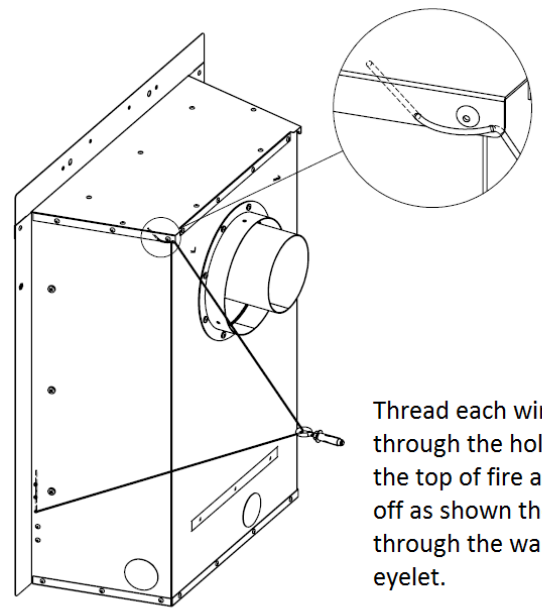

Thread each wire through the holes at the top of fire and lock off as shown then through the wall eyelet.

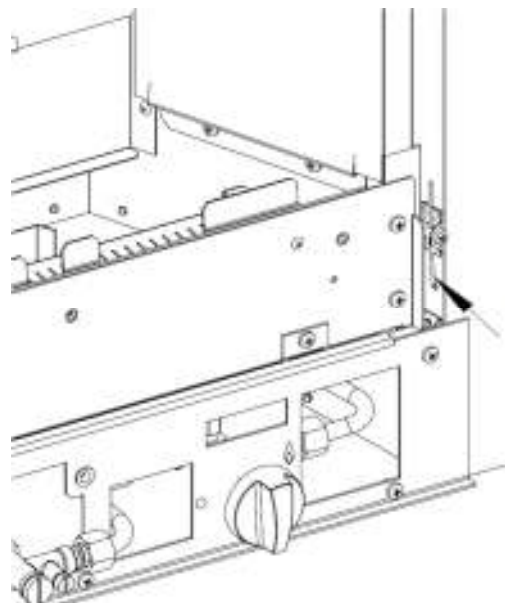

Thread the wire through the small hole below the nipple, then through the nipple as shown. Pull the wire taut to secure the appliance against the back panel. Finally tighten the small screw on the nipple.

This installation **DOES NOT** require the burner tray to be removed from the firebox. Thread the cables from the **FRONT** base of the fire at the two positions left and right. The cable can be pulled through the firebox at each side. Thread these cables **UP** through the eyelets and then through the hole and down through the slot at the top/rear of the appliance to lock.

With the **UNCUT FLUE FITTED** to the appliance, the fire can be pulled into position, temporarily, while the flue length required is confirmed. *Use the cardboard sleeve supplied in the packaging of the flue to line the outer brick flue hole. The flue can then be pushed through the hole to check fit and alignment without causing any damage to the flue or terminal.*

Cut the Flue to the Correct Length

Take a tape measure, screw driver and screws, together with the external wall plate outside to where the flue is now protruding. Slide the wall plate over the exposed flue and secure in place with the screws provided. Now measure the distance between the outside wall and the wall plate. This is the amount of flue that must be **cut off** to create the correct flue length. Remove the wall plate and remove the appliance from the opening cavity.

Ensure that this dimension is checked very carefully as removal of too much material will result in the flue being rendered useless.

Once the flue has been cut to the correct length, check that it is oriented correctly by ensuring the cover plate screw hole is top dead centre and then fitted to the fire (see diagram below). Pull the fire into place and fit the tension fittings (see page 9). With the appliance in position and secured, take the wall plate outside and fit to the exposed flue terminal. The rear face of the wall plate should be sealed with proprietary sealing compound or mortar. The wall plate should also be screwed to the wall using the fittings (screws/rawl-plugs) provided.

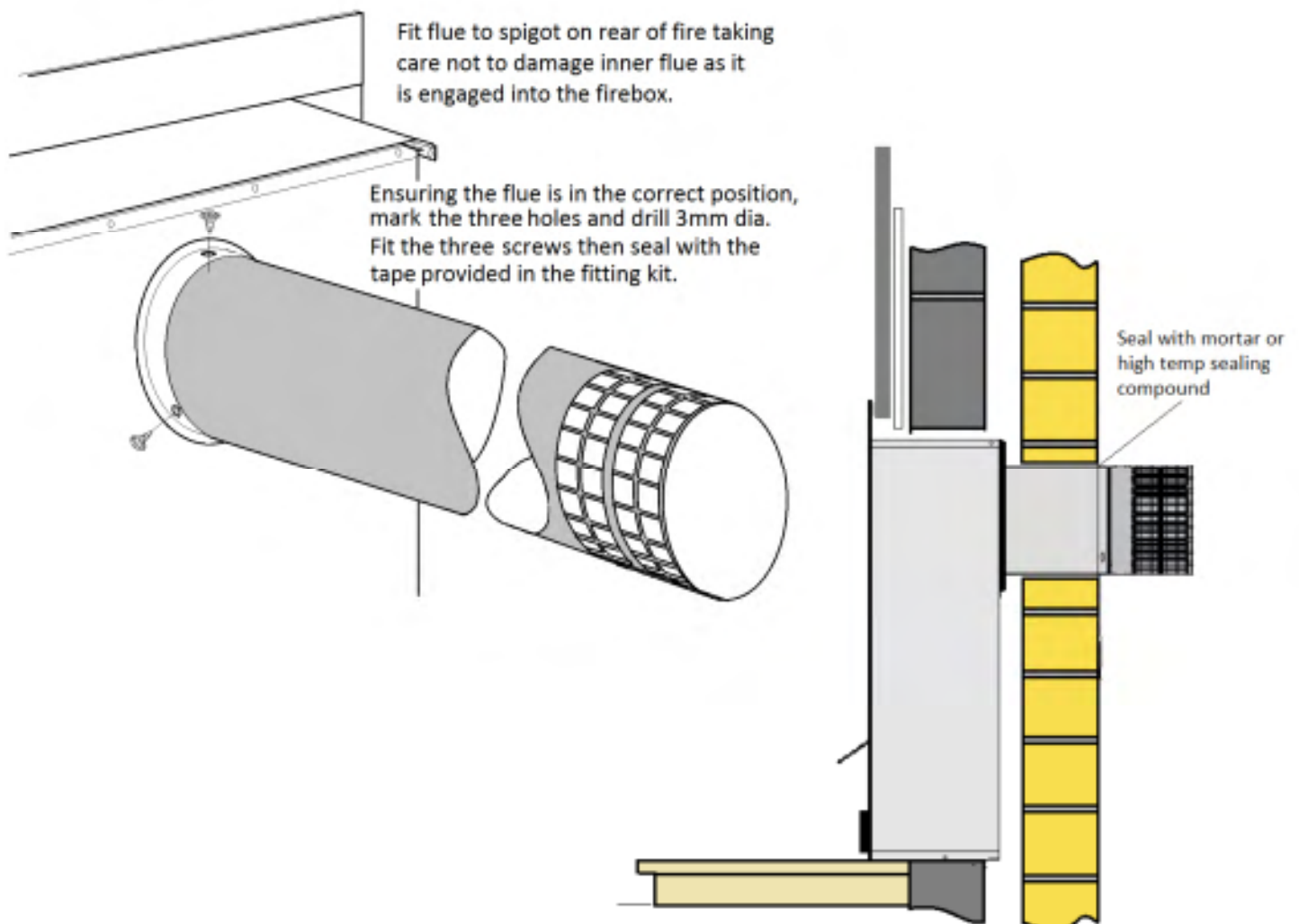

FITTING THE TERMINAL GUARD

**ONLY THE TERMINAL GUARD SUPPLIED WITH THIS PRODUCT SHOULD BE FITTED.
THIS TERMINAL GUARD ALLOWS CLEARANCE FOR BLAST FLAP CLEARANCE.**

The terminal guard can now be assembled and fitted the outside wall.

The terminal guard supplied with this appliance is required to be fitted, when installed in England or Wales if the terminal could come into contact with people moving around the building or if the terminal could become damaged.

If being installed into the republic of Ireland, refer to the current edition of IS813 'Domestic Gas Installations'

If in doubt it is recommended that the terminal guard is always fitted.

Refer to page 4 where the diagram shows where a guard should be fitted and allowable distances from the terminal.

The diagram below shows the method of assembly of the terminal guard. The guard should be secured to the wall using the screws and rawl plugs provided.

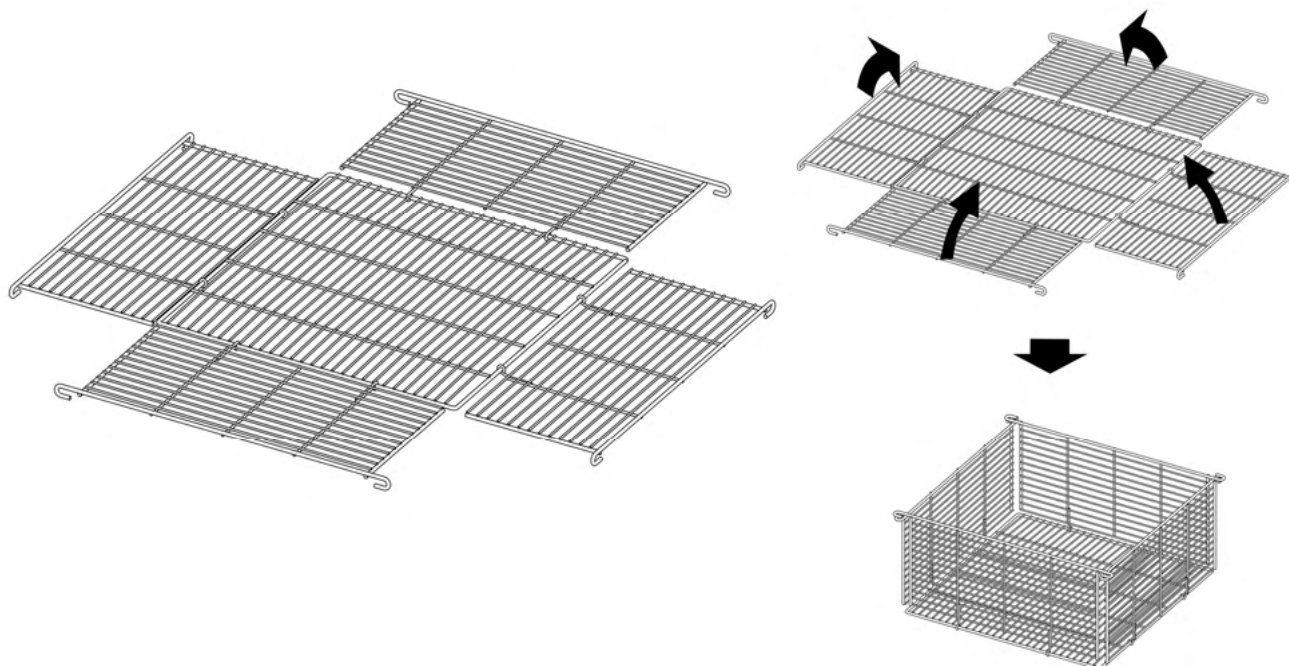

Connecting the Appliance to the Gas Supply

In all installation conditions the gas connection should be provided using 8mm (O/D) copper tubing. The relevant 'knock-out' entry point should be removed to allow the gas supply to enter the appliance. **No soldered joints** should be used with the firebox of the appliance.

Ensure a gas soundness test has been performed to ensure that the existing pipe work in the property is sound.

The connection to the appliance will be made using the 8mm restrictor isolation valve supplied with the appliance. This restrictor elbow is supplied loose and should be fitted as per the label on the instruction packet.

The data plate for the appliance can be found on the data plate on the left side flange behind the trim.

Appliance Data

Gas Type	Natural Gas
Inlet Pressure	20mbar \pm 1mbar
Gas Connection	8mm pipe
Injector	162
Pilot (Manual Control)	P-XX1313
Pilot (Slide Control)	P-XX1314
Input High Rate (Gross)	4.2kW (0.4m ³ /hr)
Input Low Rate Manual Control (Gross)	2.9kW (0.27m ³ /hr)
Input Low Rate Slide Control (Gross)	2.7kW (0.26m ³ /hr)
Battery Type (Electronic Igniter)	AA
Wall Depth (Min)*	290 mm
Wall Depth (Max)*	624 mm
Fire Depth	186mm
NOx Class	Class 3
Efficiency Class	Class 1

* The wall depth is calculated as the distance from the front face of the back panel surface to the outside face of the exterior wall.

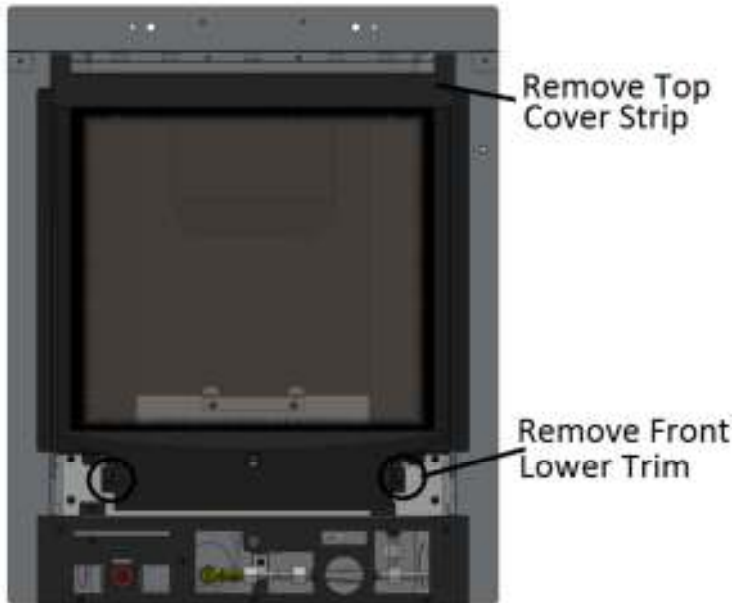

Removal of the front glass panel.

The top glass clamp is held in place with 6 screws. This panel is concealed behind the top cover strip which is held in place by two magnets. The two magnets are fitted to the top glass clamp as shown in this diagram.

First remove the two screws holding the front lower trim panel in place.

Now carefully remove the top 3 fixing screws and loosen the lower three screws whilst supporting the glass panel. Now lift the glass from the appliance.

Now the ceramics can be installed, rearranged correctly or removed for service. Correct installation of ceramics is details on pages 20 & 21.



Installation of the front glass panel.

Before replacing the glass ensure that the seal around the top and two sides of the firebox is in good condition and is securely affixed to the appliance. If the seal is damaged or loose then it should be replaced / reaffixed before the glass is replaced. This seal is important and if damaged, the appliance should not be operated.

The glass panel should be undamaged. If the glass panel is broken or cracked it should not be used. Contact the manufacturer for a suitable replacement before continuing.

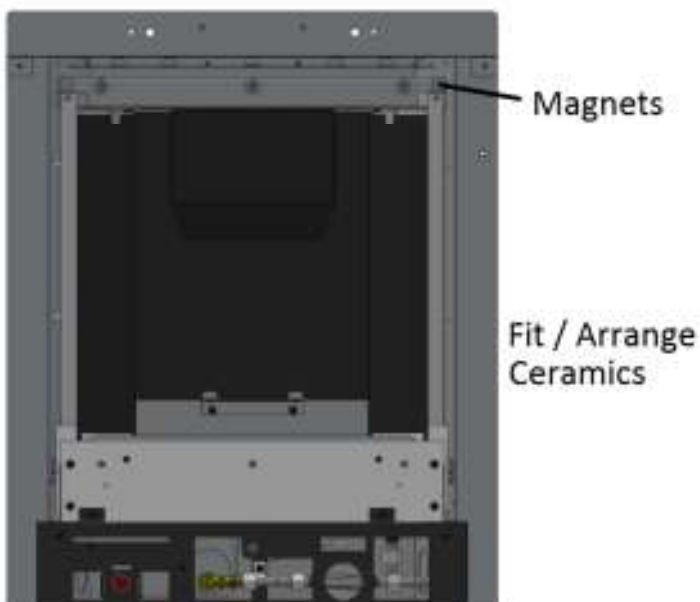

Replace the glass panel into position by locating the bottom edge around the three screw locations.

Rotate the glass panel back into position and hold whilst the top 3 screws are inserted.



Ensuring the two magnets are in the correct position (see diagram) then the top cover can be placed into position. This component is purely decorative and is used to conceal the fixing screws.

Install the ceramics and the glass panel to the appliance according to these instructions—see pages 13 and 20

Test the operating pressure of the appliance by attaching a pressure gauge to the test point of the appliance. This connection should take place when the appliance is OFF. Ensure that gas is turned on at the gas meter and purge the air from the appliance by :

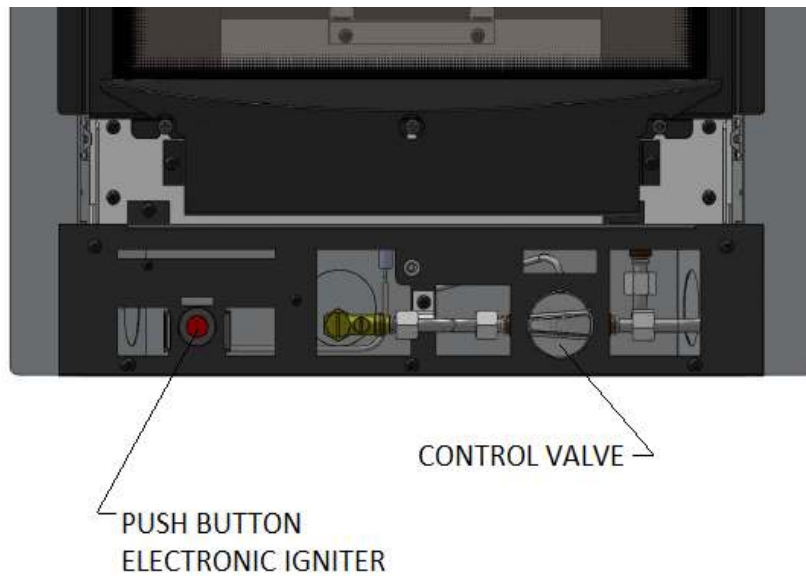

MANUAL CONTROL UNITS:

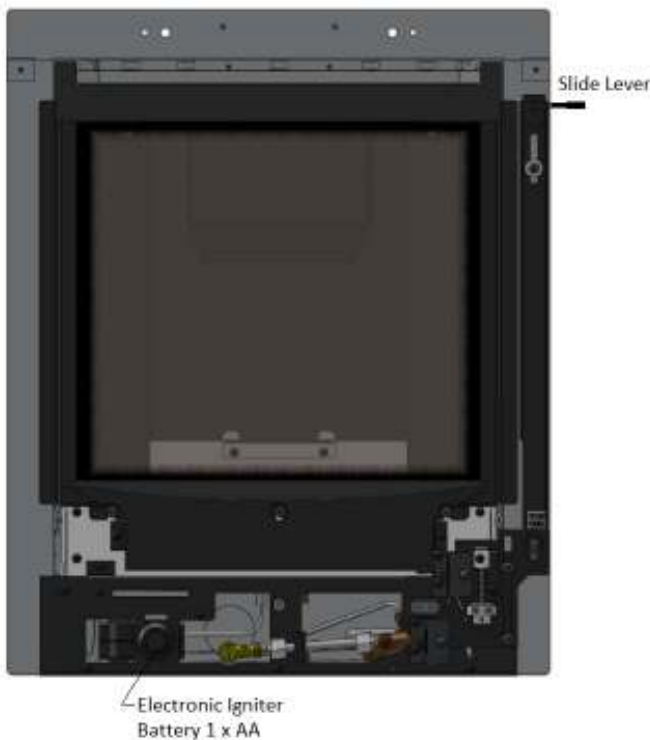

Rotating the control to the  (IGN) position and push in. Push the igniter button situated at the bottom left side of the appliance, the pilot should light. If the appliance does not light after 10 seconds the knob should be rotated back to the  (OFF) position and back to the IGN position to generate the spark at the electrode. Check that the spark is being generated correctly at the pilot assembly. Continue with this procedure until the air is purged from the appliance and the pilot is lit. Once lit hold the valve pushed in for up to 10 seconds. Once the pilot is established and secure, turn the control knob anti-clockwise to the  (HIGH) position. Allow the appliance to run for a minimum period of 5 minutes. Next check that the inlet pressure to the appliance is at 20 mbar \pm 1 mbar.



SLIDE CONTROL UNITS:

Push down the control lever fully to the  (IGN) position and hold. The spark generator should spark continuously, ensure the spark is being generated correctly at the pilot assembly. Continue with this procedure until the air is purged from the appliance and the pilot and main burner are lit. Once lit hold the lever pushed down for up to a further 10 seconds. Once the pilot is established and secure allow the lever to rise to the (LOW)  position then lift the lever to the  (HIGH) position. Allow the appliance to run for a minimum period of 5 minutes. Next check that the inlet pressure to the appliance is 20 mbar \pm 1 mbar.

It should be noted that the slide control appliance will light the pilot and main burner during the ignition process. The customer should be advised of this fact.

The flames will appear blue until the appliance reaches temperature. This can take between 10 and 20 minutes. The customer should be advised of this fact.

If the appliance is extinguished or goes out, wait for 3 minutes before attempting to relight the appliance.

Completing the Installation of the Appliance

Remove the protective covering (if applicable) from the face of the decorative trim. Fit the trim to the appliance with the magnets provided. One magnet should be placed in each corner of the trim at the top of the appliance and on each side about 120mm from the base of the appliance. In the case of slide control appliances care should be taken that the magnet does not come into contact with any moving parts of the lever mechanism. This advice should also be passed onto the consumer to ensure that they are aware of magnet positioning. A service call due to incorrect placement of magnets which cause difficulty in lighting the appliance will result in a callout charge being made.

Fix the front bars to the trim according to the instructions supplied with the appliance or position the fret in front of the fire, ensuring that the ashpan cover is sitting correctly and allows access to the controls (for manual control models).

THE INSTALLER MUST INFORM THE CUSTOMER OF THE FOLLOWING TO COMPLETE THE INSTALLATION

Demonstrate the lighting of the appliance and the controls to control the heat settings. Demonstrate how to extinguish the fire.

Demonstrate the removal of the trim and fret and how to reinstall correctly.

Discuss the removal and reinstallation of the glass and the ceramics. Explain how they should be cleaned and make the customer aware of the health and safety warning detailed later in these instructions.

Explain to the customer that the ceramics are fragile and must be treated with great care, explain that the ceramics are not covered by the warranty because of their fragility. Also explain that small hairline cracks will appear in the surface of the ceramics due to heat expansion and contraction—this is perfectly normal.

During the first several hours of use an odour will be experienced—this is normal and is the starch used in the manufacturing of the ceramic fuel bed. This odour is non toxic and will eventually disappear with use.

Advise that no rubbish should be thrown onto the appliance and that the appliance should be cleaned regularly.

A vacuum cleaner can be used but it is important that the appliance is turned off and allowed to cool before undertaking this procedure. See the separate section regarding cleaning the ceramics.

Advise the customer that the appliance should be serviced annually by a gas safe engineer to ensure the safety and integrity of the appliance.

Advise the customer that the appliance has a hot glass surface and therefore it is essential that a suitable fireguard be used for the protection of the elderly, infirm and young children. This fireguard should conform to BS8423 : 2002 (Fireguards or use with Gas Heating Appliances).

These instructions **must** be handed over to the customer once installation is complete.

Maintenance of the Appliance

The following procedures can and should be performed by the **customer** at regular intervals depending upon use of the appliance.

Appliance Technical Information

Gas Type : Natural

Gas Category : I_{2H}

Inlet Pressure: (Cold) 20mbar

Heat Input Gross : 4.2kW

Injector : 162

Destination Countries : GB

Gas Rate: 0.4m³/h

HEALTH AND SAFETY NOTICE

This appliance uses fuel effect pieces manufactured from Refractory Ceramic Fibres (RCF). Care must be taken to avoid excessive exposure to these materials as they may cause irritation to the eyes, skin, nose and throat. When Handling avoid inhaling and contact with skin and eyes. It is recommended that disposable gloves are worn in addition to a facemask and eye protection. After handling wash hands thoroughly and any other exposed parts which may have come in to contact with the material.

If a vacuum cleaner is used to clean the fuel bed or areas around the appliance there fragments of the material may have fallen it is recommended that it be of the type fitted with a HEPA filter.

Care should be taken when disposing of RCF materials. It is important to keep any dust to a minimum so it is recommended that the fuel effect components are placed into a heavy duty plastic bag. The bag should be clearly labelled **RCF WASTE**. These materials are not classified as hazardous waste and should be disposed of at a site approved for the disposal of industrial waste.

Cleaning the Appliance

Ensure the fire is turned off and has been allowed to cool for a period of at least one hour.

Metal Parts

Metal parts can be cleaned with a slightly damp cloth, once wiped, any moisture should be removed with a soft clean cloth. Do not use any abrasive cloths or cleaning solutions, these may scratch the surface.

Trim and Front Bars

There are a variety of trim and fret options which may have been supplied with your appliance and these are normally a plated material on a steel substrate. It is important that no abrasive cleaners or chemical agents are used in the cleaning of these components. It is recommended that all these surfaces are cleaned with a clean damp (not wet) cloth.

Fuel Bed

The fuel effect components supplied with this product are extremely fragile and must be handled with great care. The ceramics in this appliance are not covered by the warranty due to their fragility. This includes the RCF fibre boards in the fire box. These components will break or chip if not handled with the greatest of care.

Cleaning of these components should only be undertaken once the appliance is switched off and has been allowed to cool for a minimum period of one hour. The glass should be removed (see page 13 for full details). The ceramic components should be lifted carefully piece by piece from the appliance and placed onto a dust sheet or similar. They can be brushed gently with a soft brush to remove any dust or deposits. If you intend to use a vacuum cleaner then this should only be done once the loose deposits of soot etc have been removed. Ensure that the moulded components are structurally sound and no significant part of the moulding has broken away. If any component has broken then it should be replaced before using the appliance. Only the correct replacement part as supplied by the manufacturer shall be used in this appliance. Do not add any additional components to the fuel bed layout. It is important to note that small hairline cracks will appear in the surface of the ceramics due to heat expansion and contraction—this is perfectly normal.

Ensure that the ceramics are replaced correctly, as per the instructions in this manual.

The following procedures can and should **only** be performed by a **Gas Safe registered installer**.

This appliance should be serviced **annually** by a Gas Safe registered installer. **It is recommended that the pilot assembly is changed annually as ports can become partially blocked through ingress of particulates such as insects etc. Extended parts warranty is not valid if this part is not changed at the annual service.**

Removal / Replacement of Gas Carrying Components.

The removal and replacement of all the gas carrying components will require the removal of the burner tray. The following information details the removal of this tray. Once removed, refer to the relevant section that follows detailing the removal of the specific component (s).

- Turn off the gas supply at the isolation valve on the appliance. Ensure the appliance is cold.
- Remove the fret and the trim—put in a suitable location where they cannot be damaged or scratched in anyway.
- Remove the glass and fuel effect components - put in a suitable location where they cannot be damaged.
- Disconnect the gas supply from the restrictor elbow.
- *Slide Control models only:* Disconnect the pushrod retaining screw from the top of the rod.
- Remove the screws securing the burner tray to the firebox - note that some screws are located within the combustion chamber.
- Re-assemble the tray in the reverse order.
- Note that great care should be taken not to damage the ceramic seals which surround most of the

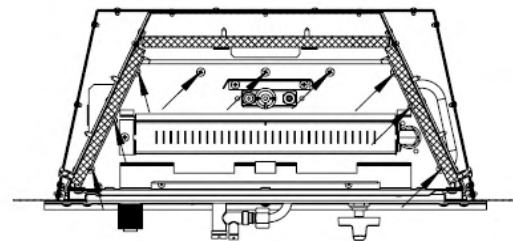
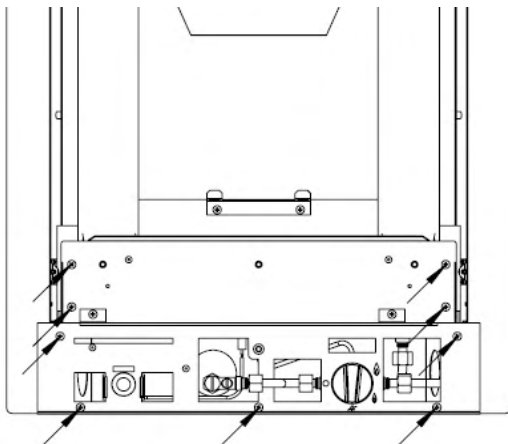

Manual Control

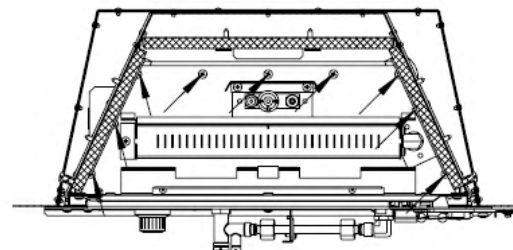
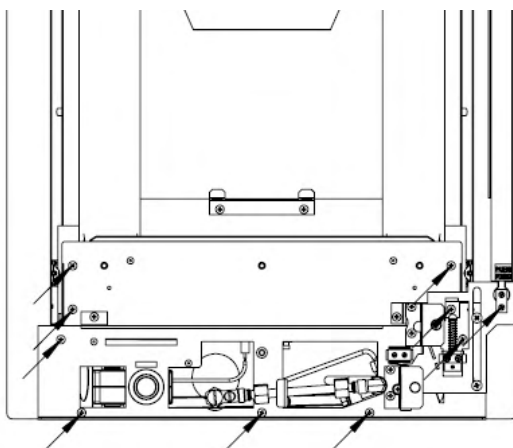

Slide Control

- Now carefully pull the burner tray from the fire box. The burner tray can now be serviced or repaired accordingly—see the following pages for information about removing and replacing serviceable components.

Removal / Replacement of Gas Carrying Components (continued)

Manual Control Valve

1. Remove the control knob from the valve.
2. Remove the locknut from the front of the valve.
3. Undo the three nuts around the periphery of the valve body—Gas Inlet / Burner / Pilot
4. Remove the thermocouple nut from the back of the valve.
5. The valve can be removed and serviced / replaced as necessary.
6. Re-assemble in reverse order.
7. Re-assemble the burner tray in to the firebox (see previous page).

Slide Control Valve

1. Remove the locknut from the front of the valve.
2. Undo the three nuts around the periphery of the valve body—Gas Inlet / Burner / Pilot.
3. Remove the thermocouple nut from the back of the valve.
4. The valve can be removed and serviced / replaced as necessary.
5. Re-assemble in reverse order.
6. Re-assemble the burner tray in to the firebox (see previous page).

Replacement of the Pilot

1. Remove the two(2) screws from the underside of the tray to release pilot.
2. Undo the pilot gas supply from the base of the pilot.
3. Remove the thermocouple nut from the back of the valve.
4. Remove the two (2) screws securing the microswitch, see diagram.
5. Remove the igniter lead from the base of the igniter.
6. The pilot assembly can be removed and replaced.
7. Re-assemble in reverse order.
8. Re-assemble the burner tray into the firebox (see previous page).

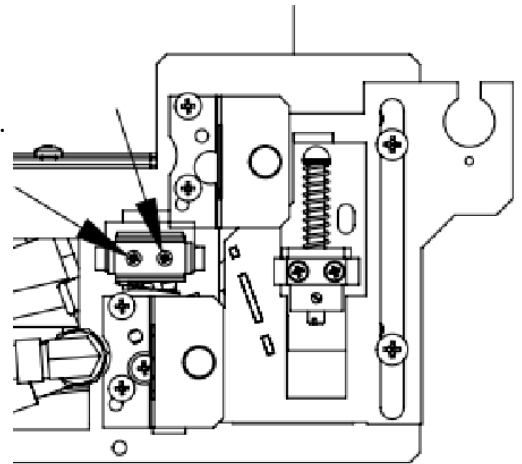

Replacement of the Injector

1. Remove the burner from the burner tray.
2. Unscrew the injector nipple from the elbow fixed to the burner tray.
3. The injector can be removed and replaced.
4. Re-assemble in reverse order.
5. Re-assemble the burner tray into the firebox (see previous page)







**Only replacement components supplied by the manufacturer should be used in the service of this appliance.
Contact details for Hearth Products Ltd can be found on the back page of these instructions.**

OPERATING INSTRUCTIONS







This appliance is available with two operating methods, namely manual control and slide control. The following instructions detail both methods of operation however the basic operation of the appliance involves the ignition of a pilot burner, then the control of the main burner with LOW and HIGH settings.

This glass panel on this appliance is very hot when in use and as with all heating appliances a fireguard should be used for the protection of children, the elderly and infirm. The fireguard should conform to BS8423 : 2002 (Fireguards or use with Gas Heating Appliances).

MANUAL CONTROL OPERATION

1. Push the control knob in fully then rotate anti-clockwise to the IGN symbol . Press the spark generator (red button) situated on the lower left hand side, which will cause a spark at the pilot and the pilot should ignite. If the pilot does not light rotate the control knob to the OFF position and retry. If the pilot does not light on the second attempt then return the control knob to the OFF position and wait for 3 minutes.
2. Once the pilot is lit keep the control knob pushed in fully for up to 10 seconds.
3. Now release the control knob, the pilot should remain lit. If it goes out, wait for 3 minutes and return to step 1.
4. To turn the appliance to the LOW setting, turn the control knob anti-clockwise to the  flame symbol.
5. To turn the appliance to the HIGH setting, turn the control knob anti-clockwise to the  flame symbol.
6. It is also possible to adjust the control knob between the  and the  flame symbols to achieve a mid setting.
7. To turn the fire off, press the knob slightly and turn to the IGN symbol  (for pilot only) or symbol  to turn off.

SLIDE CONTROL OPERATION

1. Push the control lever down fully to the IGN symbol . The spark generator should cause a repetitive spark at the pilot and the pilot and main burner should ignite. If the pilot does not light after 10 seconds then lift the control lever upwards to the OFF symbol  and wait for 3 minutes.
2. Once the pilot is lit keep the control lever pushed down fully for up to 10 seconds.
3. Now slowly lift the control lever to the  symbol, the pilot should remain lit and the burner will be in the LOW setting. If it goes out, wait for 3 minutes and return to step 1.
4. To set the appliance to the HIGH setting, lift the control lever upwards to the  flame symbol.
5. It is also possible to adjust the control knob between the  and the  flame symbols to achieve a mid setting.
6. To turn the fire off, lift the lever to the  symbol to turn off.

IMPORTANT NOTE: Should the spark generator fail to provide a spark at the electrode it may be that a small amount of soot has fallen from the fuel bed onto the pilot assembly, causing a short circuit. If this is the case, ensuring the appliance is off and cold, this area can be cleaned with the thin nozzle from a vacuum cleaner. Alternatively check the battery is in good condition—the battery access cover is at the base of the appliance just left of centre.

FUEL BED LAYOUT (COAL)

The following instructions detail how the ceramic fuel bed and loose components are to be installed onto the appliance. Great care should be taken when handling these ceramic parts as they are fragile and can easily be broken. Do not force any component into position, if it does not fit easily then you are not fitting the part correctly. These instructions can also be followed to remove or reinstall the fuel bed after cleaning. This is a procedure that can be undertaken by the customer as required and the frequency will be depend upon use. **See page 13 for glass panel removal and installation.**

Step 1

Fit the fuel bed into the appliance as shown in the picture below.



Step 2

Fit the front right side ceramic rail in front of the burner as shown in the picture below. Ensure its' lower edge is sitting down onto the support bracket.

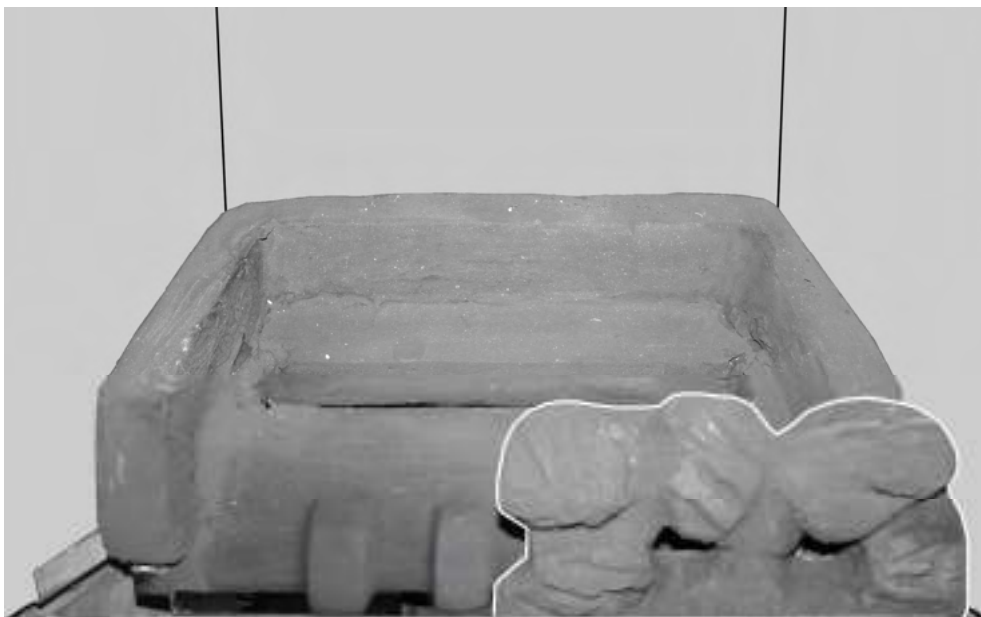

Step 3

Fit the front left side front ceramic rail in front of the burner as shown in the picture below. Ensure its' lower edge is sitting down onto the support bracket.



Step 4

Fit the upper right side ceramic rail as shown in the picture below.



Step 5

Fit the upper left side ceramic rail as shown in the picture below.



APPLIANCE COMMISSIONING CHECKLIST

It is the installers responsibility to complete the following checklist when commissioning this appliance. The information recorded on this page may be requested at the time of any warranty call made. If the information is not made available it may affect the warranty support for the customers appliance.

CHECK LISTS	PASS	FAIL
Check flue is suitable for this appliance		
Check flue flow prior to installation		
Check spillage after installation		
Check standing gas pressure		mbar
Check working pressure on full rate (Min. 18.5) Ensure all other gas appliances are running on full rate		mbar
Complete relevant section of warranty forms , complete with Gas Safe registration details		
Instruct the customer on lighting, maintenance and servicing procedures. (Including glass removal and ceramic placement)		

Gas Engineer Name	
Gas Safe Engineer Registration No.	
Gas Safe Engineer contact No.	

If you can smell gas, immediately turn off the gas supply using the control valve at the meter in your home. Do not smoke and turn off all sources of ignition, i.e. boilers or gas hobs. Open windows and doors to ventilate the room or building.

Call the Gas Emergency Service 0800 111 999 (England Scotland and Wales)
 0800 002 002 (N. Ireland)

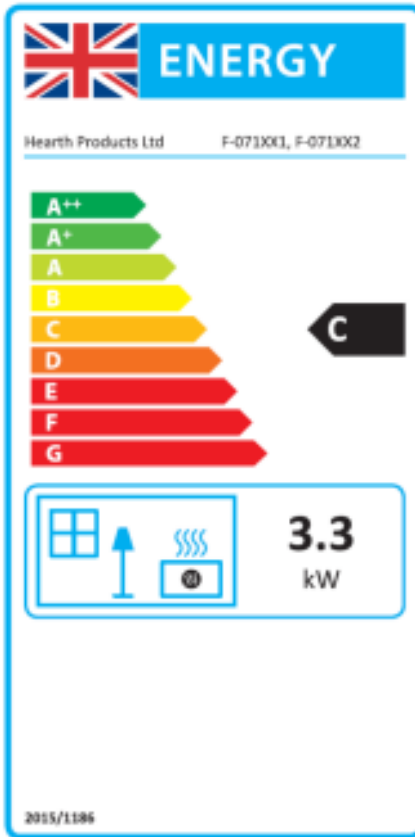

Product Fiche		
Manufacturer : Hearth Products Ltd		
Model No.	F-071XX1	F-071XX2
Fuel Type	Natural Gas I2H	Natural Gas I2H
Energy Efficiency Class	C	C
Indirect Heating Functionality	No	No
Direct Heat Output kW	3.3kW	3.3kW
Indirect Heat Output kW	N/A	N/A
EEl	77%	77%
Useful Energy Efficiency (NCV)	High : 86.2%	High : 86.2%
Useful Energy Efficiency (NCV)	N/A	N/A
Nominal Heat Output	High : 3.3kW	High : 3.3kW
Nominal Heat Output	Low : 2.1kW	Low : 2.0kW
Heat Output Temperature Control	Two Manual Stages	Two Manual Stages
Permanent Pilot Power (kW)	N/A	N/A
Space Heating Emissions NOx (GCV)	130mg/kWh	130mg/kWh

Important Note:

The energy efficiency class of this product is defined using a seasonal efficiency calculation which reduces the actual net efficiency of the product where the use of automated heat control, thermostats, window open sensors and timers are not used. This is not to be confused with the net efficiency, or useful efficiency of the appliance (shown in the tables above).

**This product MUST be installed by a Gas Safe Registered Installer. Full details are provided in this manual.
Hearth Products Ltd. Unit 14 Tollgate Industrial Estate, Stafford, ST16 3SU**

User Replaceable Parts

Part Number	Description
P-XX1181	Ceramic Fuel Bed-Coal
P-XX1182	Ceramic Front Rail– LH
P-XX1183	Ceramic Front Rail– RH
P-XX1184	Ceramic Upper – LH
P-XX1185	Ceramic Upper – RH
P-XX1395	Glass Panel



**Hearth Products Ltd
Unit 14 Tollgate Industrial Estate,
Stafford, ST16 3SU**

[Www.hearthproducts.co.uk](http://www.hearthproducts.co.uk)

Tel: 01785 225401 Fax: 01785 225501

Email: info@hearthproducts.co.uk



Due to our policy of continual product improvement, some diagrams and small details may not be accurate however if there is any concern or matter of understanding that you feel needs to be clarified please contact us directly. Our contact details are shown below.